

MODELS 20, 26, 30 HP MITSUBISHI MAIN HARNESS

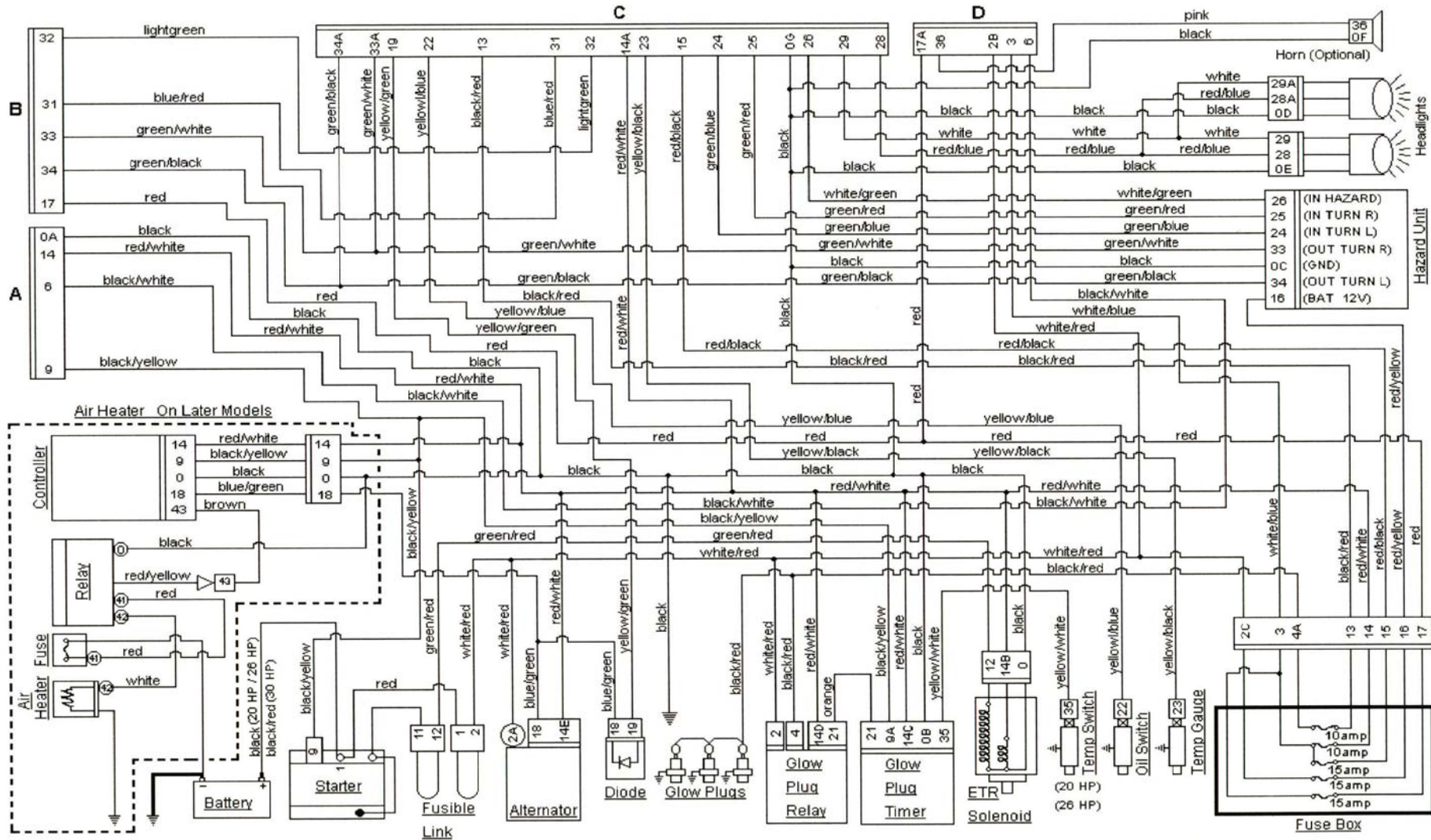

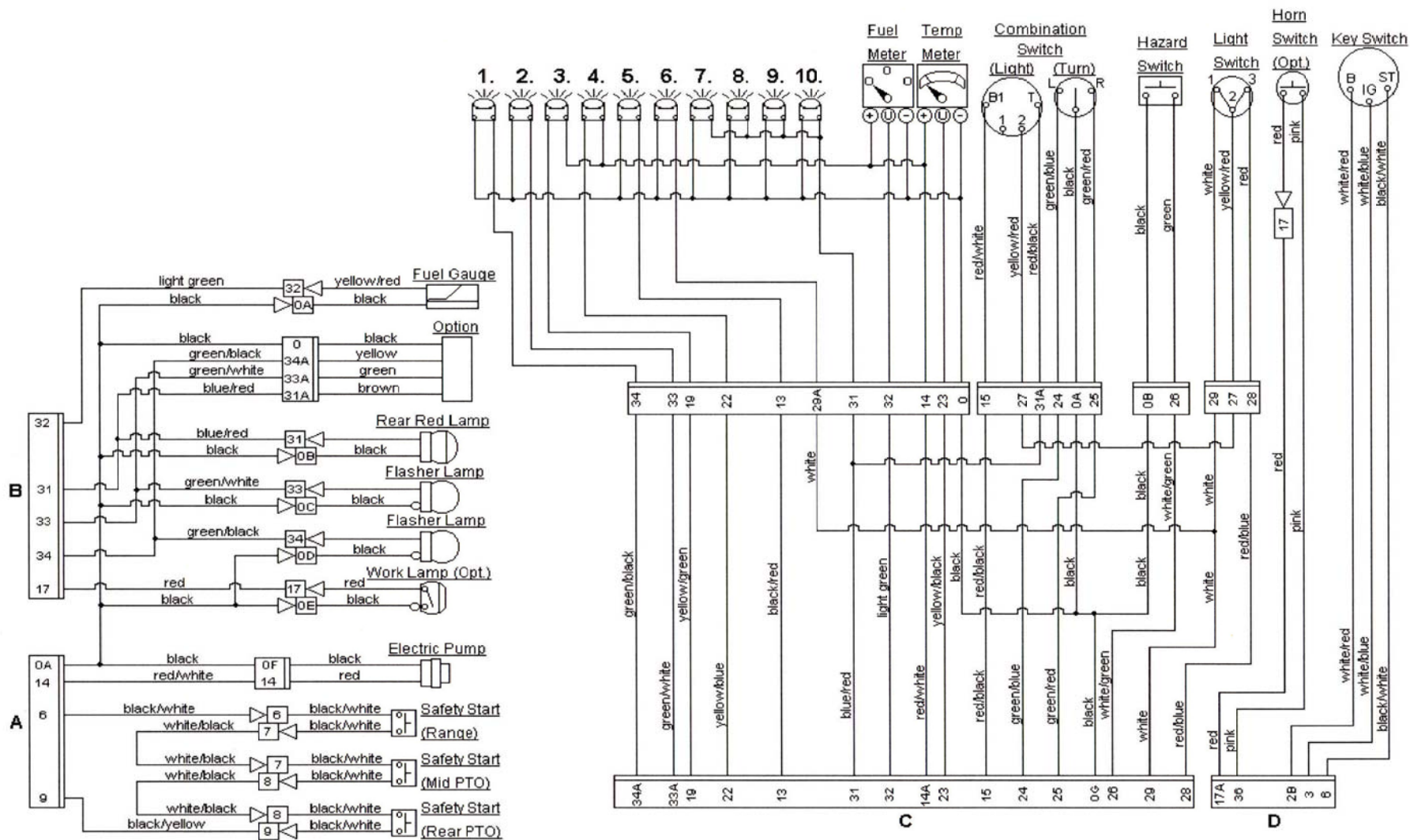

- | | | |
|-------------------------|---------------|----------------|
| 1. Left Turn Indicator | 5. Glow Lamp | 9. Panel Lamp |
| 2. Right Turn Indicator | 6. High Beam | 10. Panel Lamp |
| 3. Charging Light | 7. Panel Lamp | |
| 4. Oil Light | 8. Panel Lamp | |

MODELS
20, 26, 30 HP MITSUBISHI DASH HARNESS